

AL Lever Hoists (Aluminium Alloy)
0.25Ton-0.5Ton

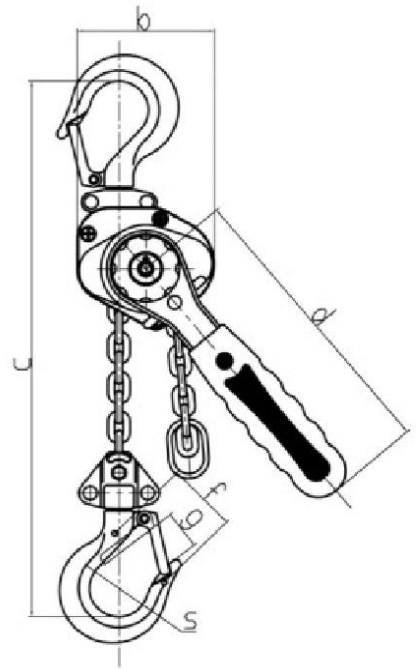
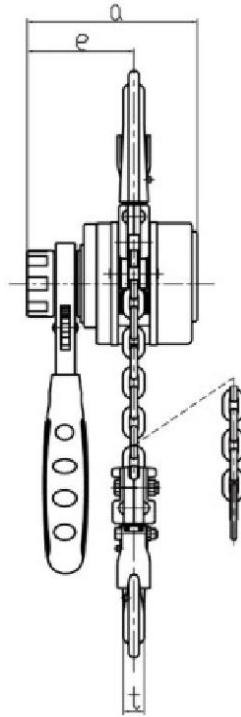

Specifications

Type	Capacity (t)	Standard Lift (m)	Effort required to lift full load (N)	Load Chain	Test Load (t)	Weight (kg)	Additional Weight per 1m Lift(kg)
				Diameter (mm)×chain falls			
AL0025	0.25	1	162	4.0× 1	0.375	2	0.3
AL005	0.5		200	5.0× 1	0.75	3.2	0.6

Dimensions (mm)

Type	Capacity (t)	a	b	c	d	e	f	g	s	t
AL0025	0.25	87	68	200	145	55.5	35.5	21	32	11
AL005	0.5	100.5	81	250	160	62.5	42	24.5	34.5	12