

V3 Lever Hoists  
**0.25Ton-0.5Ton**

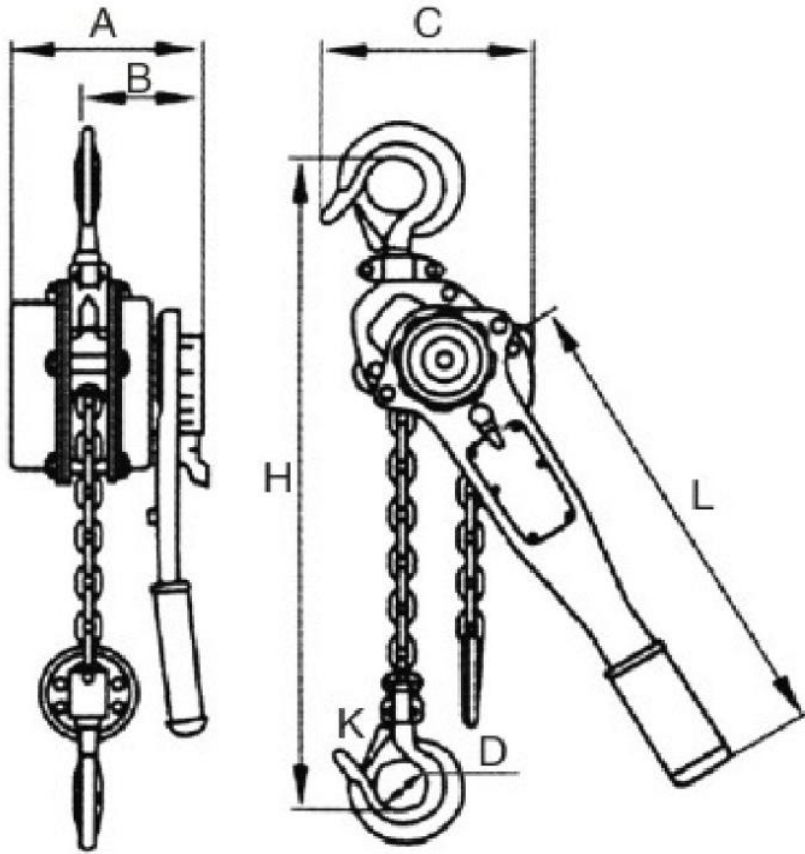

**Specifications**

Type	Capacity (t)	Standard Lift (m)	Effort required to lift full load (N)	Load Chain	Test Load (t)	Weight (kg)	Additional Weight per 1m Lift(kg)
				Diameter (mm) × chain falls			
V30025	0.25	1	162	4 × 1	0.375	1.8	0.3
V3005	0.5	1	200	5 × 1	0.75	1.8	0.6