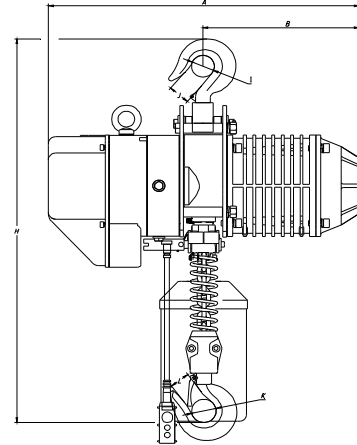
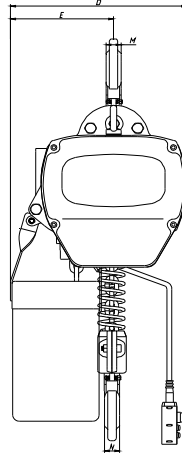

## RM Electric Chain Hoists (With Hook Suspension)

**0.5Ton-10Ton**

**Specifications**

Type	Capacity (t)	Lifting Speed (m/min)		Standard Lift (m)	Lifting Motor		Load Chain Diameter (mm) ×chain falls	Test Load (t)	Weight (kg)	Additional Weight per 1m Lift (kg)
		50Hz	60Hz		Power (kw)	Rotation Speed (r/min)				
RM00501S	0.5	6.8	8.2	3	0.75	1440 (50Hz) 1728 (60Hz)	6.3 × 1	0.625	47	0.8
RM0101S	1	6.6	7.9		1.5		7.1 × 1	1.25	61	1.1
RM0102S	1	3.4	4.1		0.75		6.3 × 2	1.25	52	1.6
RM01501S	1.5	8.8	10.6		3.0		10.0 × 1	1.875	108	2.3
RM0201S	2	6.6	7.9		3.0		10.0 × 1	2.5	115	2.3
RM0202S	2	3.3	4.0		1.5		7.1 × 2	2.5	73	2.2
RM02501S	2.5	5.4	6.5		3.0		11.2 × 1	3.125	116	2.8
RM0301S	3	5.4	6.5		3.0		11.2 × 1	3.75	122	2.8
RM0302S	3	4.4	5.3		3.0		10.0 × 2	3.75	131	4.7
RM0303S	3	2.2	2.6		1.5		7.1 × 3	3.75	85	3.3
RM0502S	5	2.7	3.2		3.0		11.2 × 2	6.25	151	5.6
RM07503S	7.5	1.8	2.2		3.0		11.2 × 3	9.4	266	8.4
RM1004S	10	2.7	3.2		3.0×2		11.2 × 4	12.5	300	11.2

**Dimensions (mm)**

Type	Capacity (t)	Headroom	A	B	D	E	I	J	K	L	M	N
		H										
RM00501S	0.5	550	460	230	280	160	Φ35	25	Φ35	25	17	17
RM0101S	1	650	520	260	300	176	Φ40	31	Φ40	31	22	22
RM0102S	1	670	460	230	280	205	Φ40	31	Φ40	31	22	22
RM01501S	1.5	800	615	295	430	265	Φ47	40	Φ47	38	30	30
RM0201S	2	800	615	295	430	265	Φ47	40	Φ47	38	30	30
RM0202S	2	835	520	260	300	236	Φ47	38	Φ47	38	30	30
RM02501S	2.5	845	615	295	430	265	Φ58	47	Φ58	47	36	36
RM0301S	3	845	615	295	430	265	Φ58	47	Φ58	47	36	36
RM0302S	3	950	615	295	430	320	Φ58	47	Φ58	47	36	36
RM0303S	3	950	520	260	350	205	Φ59	48	Φ59	48	35	35
RM0502S	5	1030	615	295	430	325	Φ60	48	Φ60	48	43	43
RM07503S	7.5	1200	615	295	505	320	Φ85	31	Φ85	80	85	55
RM1004S	10	1400	630	315	/	890	Φ85	80	Φ85	80	104	55