

RM Electric Chain Hoists (With Hook Suspension)

0.5Ton-10Ton

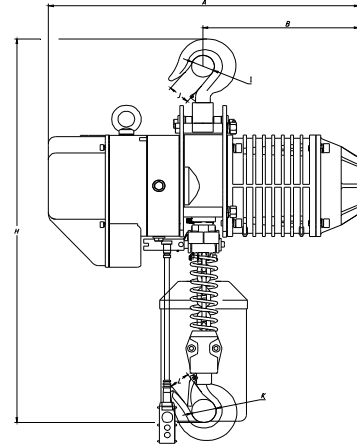
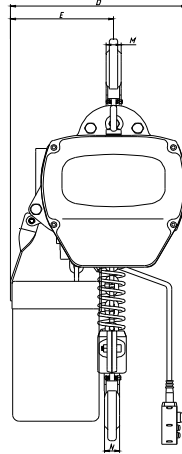

Specifications

Type	Capacity (t)	Lifting Speed (m/min)		Standard Lift (m)	Lifting Motor		Load Chain Diameter (mm) ×chain falls	Test Load (t)	Weight (kg)	Additional Weight per 1m Lift (kg)
		50Hz	60Hz		Power (kw)	Rotation Speed (r/min)				
RM00501S	0.5	6.8	8.2	3	0.75	1440 (50Hz) 1728 (60Hz)	6.3 × 1	0.625	47	0.8
RM0101S	1	6.6	7.9		1.5		7.1 × 1	1.25	61	1.1
RM0102S	1	3.4	4.1		0.75		6.3 × 2	1.25	52	1.6
RM01501S	1.5	8.8	10.6		3.0		10.0 × 1	1.875	108	2.3
RM0201S	2	6.6	7.9		3.0		10.0 × 1	2.5	115	2.3
RM0202S	2	3.3	4.0		1.5		7.1 × 2	2.5	73	2.2
RM02501S	2.5	5.4	6.5		3.0		11.2 × 1	3.125	116	2.8
RM0301S	3	5.4	6.5		3.0		11.2 × 1	3.75	122	2.8
RM0302S	3	4.4	5.3		3.0		10.0 × 2	3.75	131	4.7
RM0303S	3	2.2	2.6		1.5		7.1 × 3	3.75	85	3.3
RM0502S	5	2.7	3.2		3.0		11.2 × 2	6.25	151	5.6
RM07503S	7.5	1.8	2.2		3.0		11.2 × 3	9.4	266	8.4
RM1004S	10	2.7	3.2		3.0×2		11.2 × 4	12.5	300	11.2

Dimensions (mm)

Type	Capacity (t)	Headroom		A	B	D	E	I	J	K	L	M	N
		H	H										
RM00501S	0.5	550	550	460	230	280	160	Φ35	25	Φ35	25	17	17
RM0101S	1	650	650	520	260	300	176	Φ40	31	Φ40	31	22	22
RM0102S	1	670	670	460	230	280	205	Φ40	31	Φ40	31	22	22
RM01501S	1.5	800	800	615	295	430	265	Φ47	40	Φ47	38	30	30
RM0201S	2	800	800	615	295	430	265	Φ47	40	Φ47	38	30	30
RM0202S	2	835	835	520	260	300	236	Φ47	38	Φ47	38	30	30
RM02501S	2.5	845	845	615	295	430	265	Φ58	47	Φ58	47	36	36
RM0301S	3	845	845	615	295	430	265	Φ58	47	Φ58	47	36	36
RM0302S	3	950	950	615	295	430	320	Φ58	47	Φ58	47	36	36
RM0303S	3	950	950	520	260	350	205	Φ59	48	Φ59	48	35	35
RM0502S	5	1030	1030	615	295	430	325	Φ60	48	Φ60	48	43	43
RM07503S	7.5	1200	1200	615	295	505	320	Φ85	31	Φ85	80	85	55
RM1004S	10	1400	1400	630	315	/	890	Φ85	80	Φ85	80	104	55