

Hand Pallet Trucks

2Ton-5Ton

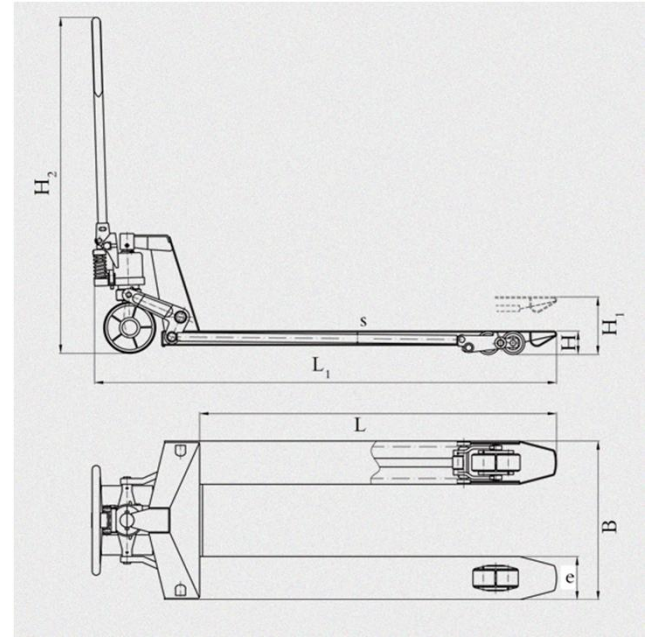

Specifications

Type	Capacity (t)	Min.Fork Height	Lifting Height (Max.Fork Height)	Min.Fork Height	Total Height	Overall Length	Fork Size	Loading Wheel (Fork Double Wheel)	Steering Wheel (Big Wheel)	Turing Radius	Material of wheel	Weight (kg)
HPT02A HPT02B	2	80	200	80	1200	1480/1580	150*55	φ80*68 (4 pcs)	φ180*50 (2 pcs)	1200/1300	Nylon/PU/Rubber	68
HPT025A HPT025B	2.5				1200		150*55			1200/1300		70
HPT03A HPT03B	3				1200		160*60			1200/1300		73
HPT05A HPT05B	5				1250		160*60			1300/1370		75
												78
												80
					128							
					130							

Dimensions (mm)

Type	Capacity (t)	Fork overall width (B)	Fork length (L)	Ground Clearance, Center of Wheelbase	Single fork width (e)	H1	H	s	H2 min./max.	L1	Details of wheel locking system
HPT02A HPT02B	2	550 685	1100/1200	30	160	230	85	3	715/1280	1588	Hydraulic
HPT025A HPT025B	2.5	550 685				365	85	3			
HPT03A HPT03B	3	550 685				365	85	4			
HPT05A HPT05B	5	685 685				370	85	16			