

ZD 型

锥形转子制动电动机 ZD conical rotor brake motor

产品特性：

ZD型锥形转子三相异步电动机是电动葫芦的起升电机，本系列电动机不附加任何电磁设备，具有自动刹车功能。在切断电源时，依靠转子上压力弹簧产生摩擦力矩制动，可使电机在短时间内停止转动。该电机起动力矩大、制动可靠，可频繁起动。已通过ISO9001国际质量体系认证。

本系列电动机适用于要求起动力矩较大及制动力矩较大的驱动装置，如电动葫芦、电动小车及起重机的大车运行机构，也适用于起重运输机械、机床、生产流水线和其他要求迅速制动的场合中使用。

Product characteristics:

ZD series of conical rotor three-phase asynchronous motor is a hoist motor used in electric hoist. The series of motors have automatic braking function without any additional electromagnetic equipment. When the power supply is cut off, the friction torque brake is produced by the upper pressure spring on the rotor, which can stall the motor in a short time. The motor has the characteristics of large starting torque, reliable braking and frequent starting. In addition, it has passed ISO9001 international quality system certification.

The series of motors are suitable for driving devices requiring large starting torque and braking torque, such as electric hoist, electric trolley and crane crane trolley operating mechanism, also suitable for lifting and transport machinery, machine tools, process line and other occasions requiring rapid braking.



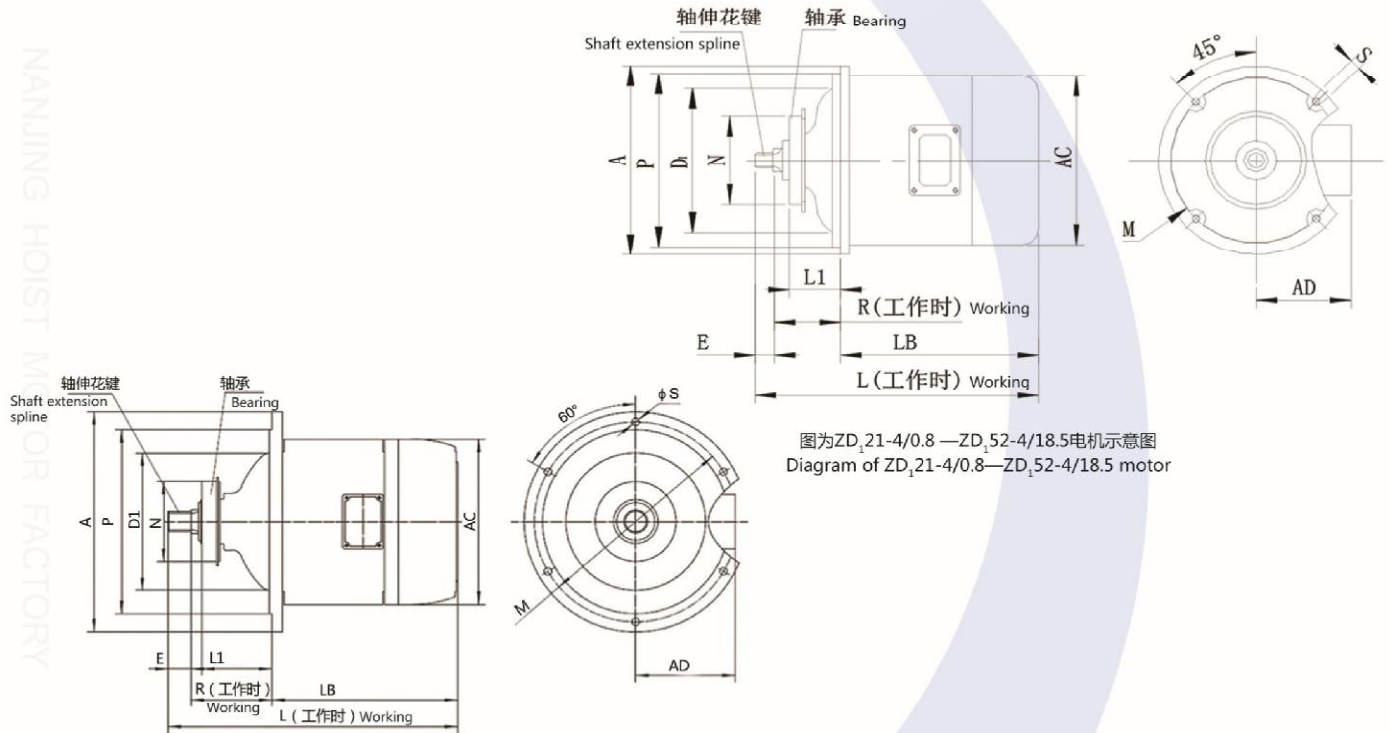

图为ZD₁21-4/0.8—ZD₁52-4/18.5电机示意图
Diagram of ZD₁21-4/0.8—ZD₁52-4/18.5 motor

图为ZD₁52-4/18.5D—ZDX62-6/18.5电机示意图
Diagram of ZD₁52-4/18.5D—ZDX62-6/18.5 motor

ZD₁系列电动机外形及安装尺寸图、表(mm)

ZD₁ series of motor outline and installation dimension chart/ table

型号及功率(kW) Type and power (kW)	安装尺寸及公差 Installation dimensions and tolerances												外形尺寸 outline dimension			
	轴伸 Shaft extension	矩形花键 Square spline	E	L1	R (工作时) Working	A	P	M	D1	N	S	凸缘孔数 Number of flange holes	AC	AD	LB	L (工作时) Working
		三角花DZ Trigonometric spline														
ZD ₁ 21-4/0.8	6D-20f9×16×4d11		22	59.5	70	-	220	196	177	110	10		209	110	233	325
ZD ₁ 22-4/1.5					71	-	235	205	172					114	261	354
ZD ₁ 31-4/3.0	6D-28f9×23×6c11		30	81	103	-	290	260	220	120	13		272	143	288	421
ZD ₁ 32-4/4.5					94	-	320	286	223					150	310	434
ZD ₁ 41-4/7.5	10D-35d9×28×4c11		35	97	118	-	380	340	260	160		4	328	170	361	514
ZD ₁ 51-4/13	10D-40d9×32×5c11		38	137	170	-	455	415	300	200	17		410	210	424	634
ZD ₁ 52-4/18.5	10D-45c8×36×5c11		55	168	187	-							530	450	490	19
ZD ₁ 52-4/18.5D				158		200	550	460	500	345	459	714				
ZDX62-4/24	10D-52d9×42×6c11		73	173	200	550	460	500	345	19	6		414	245	493	748
ZDX62-6/18.5													414	245	493	748