

# Super Long Hand Pallet Trucks

## 2Ton

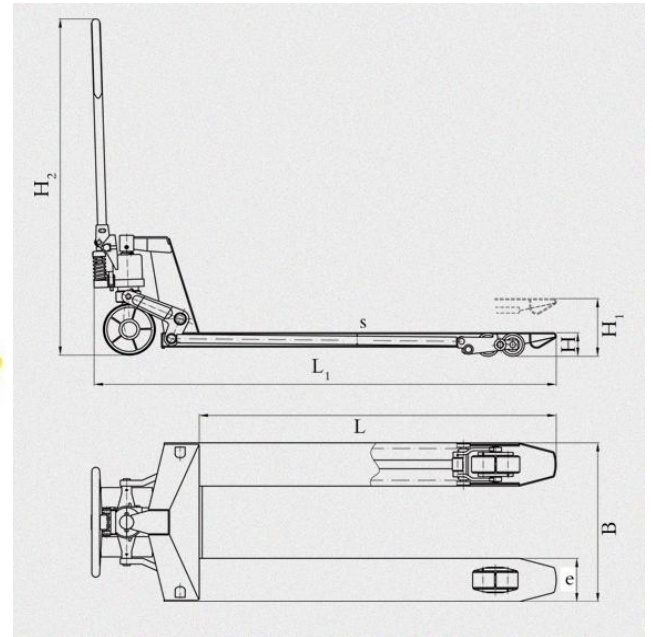

### Specifications

Type	Capacity (t)	Min.Fork Height	Lifting Height (Max.Fork Height)	Min.Fork Height	Total Height	Overall Length	Fork Size	Loading Wheel (Fork Double Wheel)	Steering Wheel (Big Wheel)	Turing Radius	Material of wheel	Weight (kg)
HPT02A	2	80	200	80	1200	2180	150*55	φ80*68 (4 pcs)	φ180*50 (2 pcs)	1200/1300	Nylon/PU/Rubber	88
HPT02B												90

### Dimensions (mm)

Type	Capacity (t)	Fork overall width (B)	Fork length (L)	Ground Clearance, Center of Wheelbase	Single fork width (e)	H1	H	s	H2 min./max.	L1	Details of wheel locking system
HPT02A	2	550	1800	30	160	230	85	3	715/1280	2180	Hydraulic
HPT02B		685					75				