

Vacuum Stone Lifters

150kgs-2000kgs

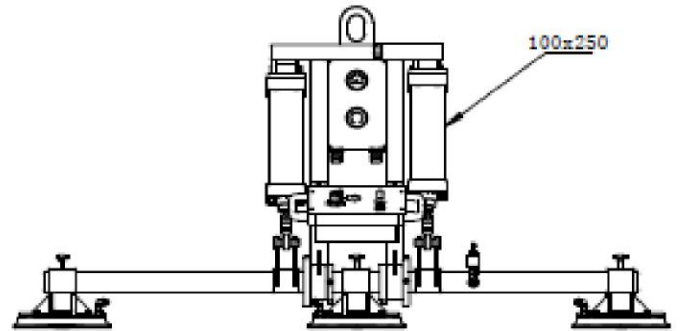
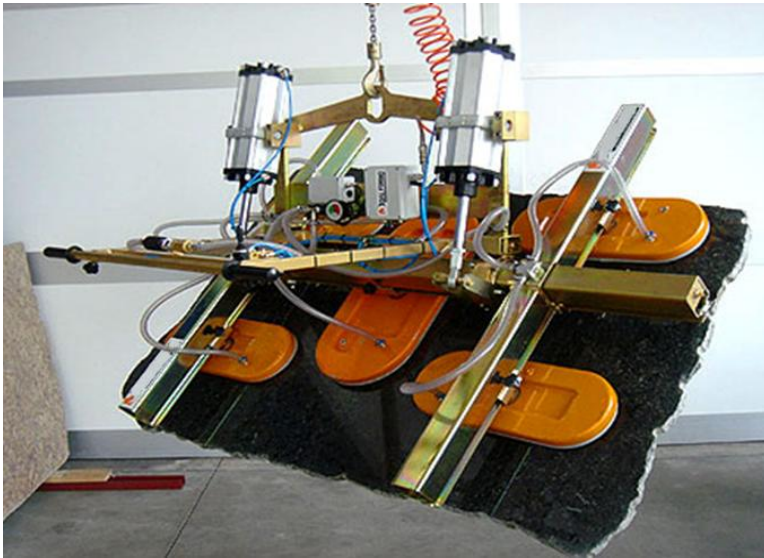

Specifications

Type	Loading Capacity (kg)	Pad Dimension(mm)	Pad Number	Required	Turning Degree	Vacuum On/Off	Vacuum Flow(L/M)	Turning Unit	Cylinder Number
VSL15	150	230*300	2	5bar	0-85°	Manual	160	Manual tilting with lock for horizon and vertical	1
VSL25	250	250*450	1				160	Manual tilting with lock for horizon and vertical	1
VSL30A	300	400*500	1				160	Manual tilting with lock for horizon and vertical	1
VSL30B	300	250*450	2				200	Pneumatic tilting, tilting speed controllable by sense	1
VSL35	350	230*300	5				200	Manual tilting with lock for horizon and vertical	1
VSL40	400	250*450	2				160	Manual tilting with lock for horizon and vertical	2
VSL50A	500	250*450	3				200	Manual tilting with lock for horizon and vertical	2
VSL50B	500	250*450	4				200	Pneumatic tilting, tilting speed controllable by sense	2
VSL50C	500	300*450	6				300	Pneumatic tilting, tilting speed controllable by sense	2
VSL60	600	250*450*4;350*550*1	5				420	Pneumatic tilting, tilting speed controllable by sense	2
VSL120	1200	500*800	8				650	Pneumatic tilting, tilting speed controllable by sense	4
VSL200	2000	400*1500	10				780	Pneumatic tilting, tilting speed controllable by sense	4